

SMT CURRENT SENSE TRANSFORMERS

S-822X Series



- Height: 5.1mm Max
- Footprint: 8.4mm x 7.2mm Max
- Current Rating: up to 10A
- Frequency Range: 50kHz to 1MHz
- Reverse Polarity version of S-820X

Mechanical

Schematic

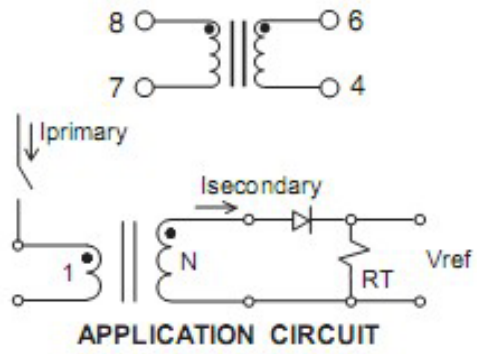
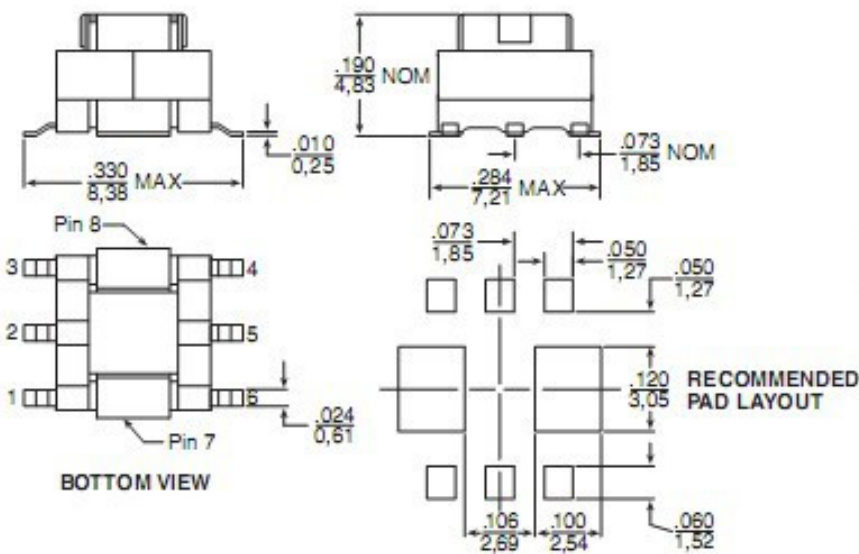

Weight.....0.34 grams
 Tray.....120/tray
 Tape & Reel..... 900/reel
 Coplanarity..... 0.006 inches

Dimensions: $\frac{\text{Inches}}{\text{mm}}$

Unless otherwise specified, all tolerances are $\pm \frac{.010}{0,25}$